

Hardware Accelerated Collision Detection using Bounded-Error Fixed-Point Arithmetic

by **Andreas Raabe**¹, **Stefan Hochgürtel**¹,
Joachim K. Anlauf¹, **Gabriel Zachmann**²



Computer-Graphic ²

TU Clausthal

Technical Computer
Science ¹



universität**bonn**

DFG-Project CollisionChip ZA292/2-1
www.collisionchip.de

Hierarchical Collision Detection

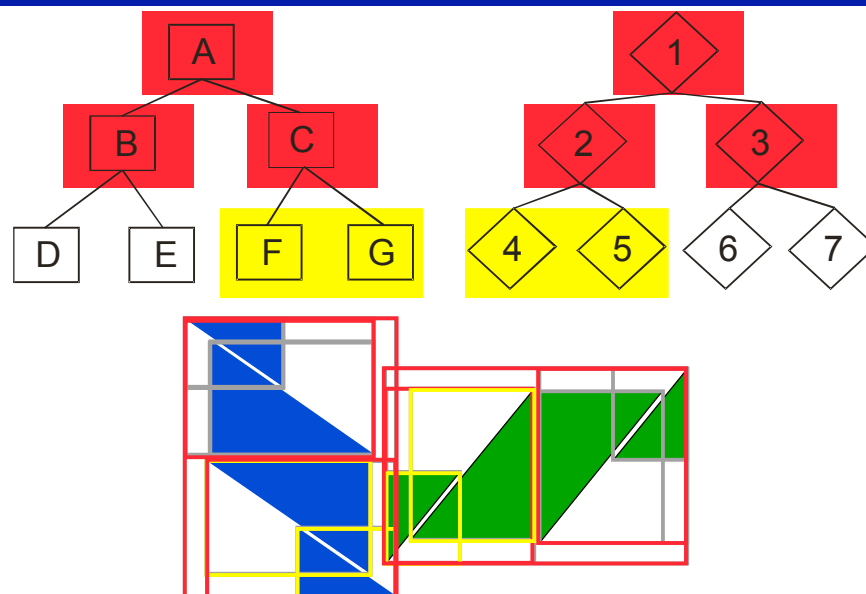

k-DOPs

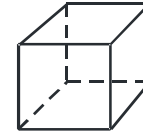
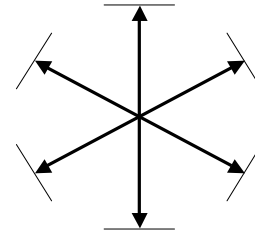
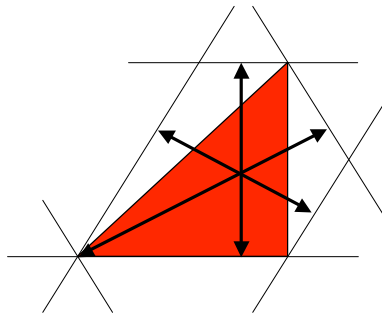

6-DOP

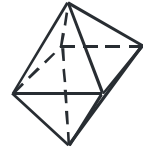

8-DOP

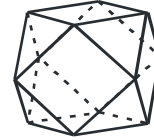

14-DOP

A DOP consists of $k/2$ pairs of antiparallel hyperplanes with fixed orientation.

3

Separating Axis Test (SAT)

- SAT-Algorithm:
 - Choose Testaxis L
 - Project onto L
 - Intervals are separated
=> BVs are separated

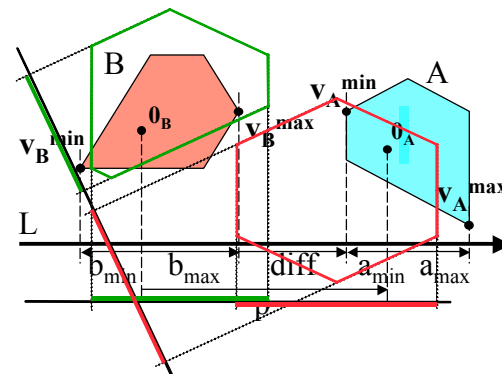

- Mathematics:

$$a_{\min} = v_A^{\min} \cdot L$$

$$a_{\max} = v_A^{\max} \cdot L$$

$$\text{diff}_1 = (a_{\min} + p) - b_{\max}$$

$$\text{diff}_2 = b_{\min} - (a_{\max} + p)$$

$$\text{Separation on L: } 0 < \text{diff} = \max(\text{diff}_1, \text{diff}_2)$$

4

SAT for k-DOPs

- **Individual:**
 - DOP-Coefficients a_i
- **Identical within Hierarchy:**
 - Orientations A_i
 - Correspondencies j_A (A_i of v_A^{\min})

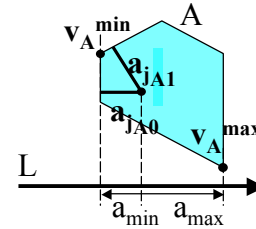

- **Mathematics:**

$$\begin{aligned}
 v_A^{\min} &= (a_{j_{A0}} \ a_{j_{A1}} \ a_{j_{A2}}) \cdot (A_{j_{A0}} \ A_{j_{A1}} \ A_{j_{A2}})^{-1} \\
 a_{\min} &= v_A^{\min} \cdot L \\
 &= (a_{j_{A0}} \ a_{j_{A1}} \ a_{j_{A2}}) \cdot (A_{j_{A0}} \ A_{j_{A1}} \ A_{j_{A2}})^{-1} \cdot L \\
 &= (a_{j_{A0}} \ a_{j_{A1}} \ a_{j_{A2}}) \cdot P_A \\
 a_{\max} &= (a_{j_{A0+k/2}} \ a_{j_{A1+k/2}} \ a_{j_{A2+k/2}}) \cdot (-P_A)
 \end{aligned}$$

5

SAT for k-DOPs (2)

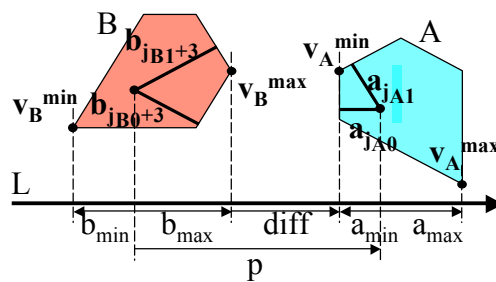

- $diff_1 = (a_{\min} + p) - b_{\max}$
 $= (a_{j_{A0}} \ a_{j_{A1}} \ a_{j_{A2}}) \cdot P_A + (b_{j_{B0+k/2}} \ b_{j_{B1+k/2}} \ b_{j_{B2+k/2}}) \cdot P_B + p$

6

Floating-Point vs. Fixed-Point Arithmetic

Floating-Point

- Large

- Large

+ High

Circuit Size

Development overhead

Accuracy

Fixed-Point

+ Small

+ Small

- Low

7

Fixed-Point (Calculation)

- Rounding of data**

$$p - p' \leq 2^{-z}$$

$$a_i' - a_i \leq 2^{-b}$$

$$P_{Ai} - P_{Ai}' \leq 2^{-c}$$

- No „false negatives“:**

$$\text{diff}_1 = (a_{jA0} \ a_{jA1} \ a_{jA2}) \cdot P_A + (b_{jB0+k/2} \ b_{jB1+k/2} \ b_{jB2+k/2}) \cdot P_B + p$$

$$\text{diff}_1' = (a_{jA0}' \ a_{jA1}' \ a_{jA2}') \cdot P_A' + (b_{jB0+k/2}' \ b_{jB1+k/2}' \ b_{jB2+k/2}') \cdot P_B' + p' + \text{SN}(a_{jA0}' \ a_{jA1}' \ a_{jA2}') \cdot 2^{-c} + \text{SN}(b_{jB0+k/2}' \ b_{jB1+k/2}' \ b_{jB2+k/2}') \cdot 2^{-c}$$

- Possible error becomes larger (more „false positives“)**

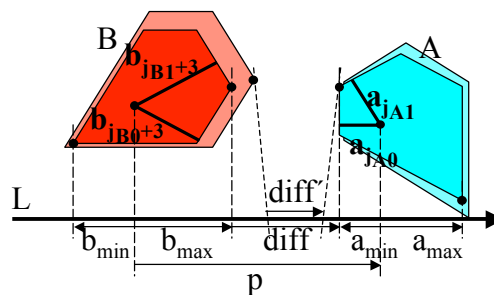

8

Fixed-Point (Error-Bound)

- **Rounding:**

$$p - p' \leq 2^{-z} \quad a_i' - a_i \leq 2^{-b} \quad P_{Ai} - P_{Ai}' \leq 2^{-c}$$

$diff_1' =$

$$(a_{jA0}' a_{jA1}' a_{jA2}') \cdot P_A' + (b_{jB0+k/2}' b_{jB1+k/2}' b_{jB2+k/2}') \cdot P_B' + p' \\ + SN(a_{jA0}' a_{jA1}' a_{jA2}') \cdot 2^{-c} + SN(b_{jB0+k/2}' b_{jB1+k/2}' b_{jB2+k/2}') \cdot 2^{-c}$$

- **Error-Bound**

- Assumption: no acute angles between DOP-faces

$$err := diff - diff'$$

$$0 \leq err \leq \sqrt{3} \cdot 2^{-b+1} + 6 \cdot 2^{-c} + 2^{-z}$$

9

Architecture

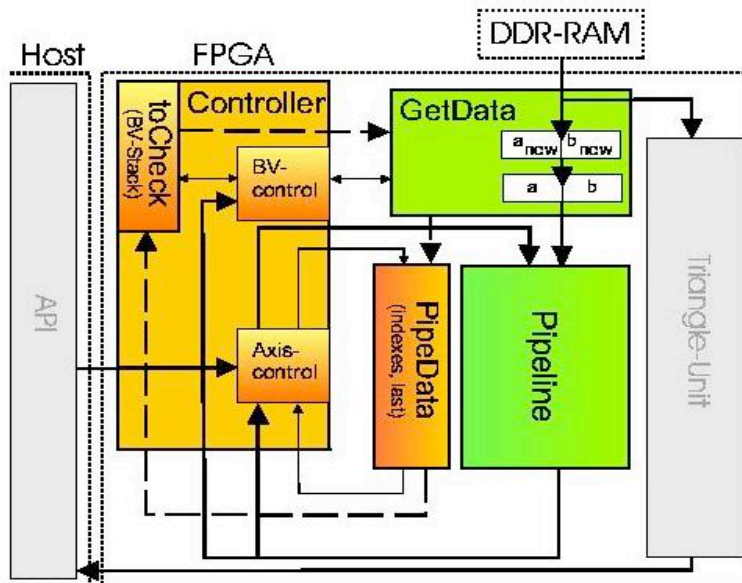

10

Benchmark



- Converge two identical objects
- Rotate one
- Average time to find all intersecting triangles for every distance

11

Benchmark

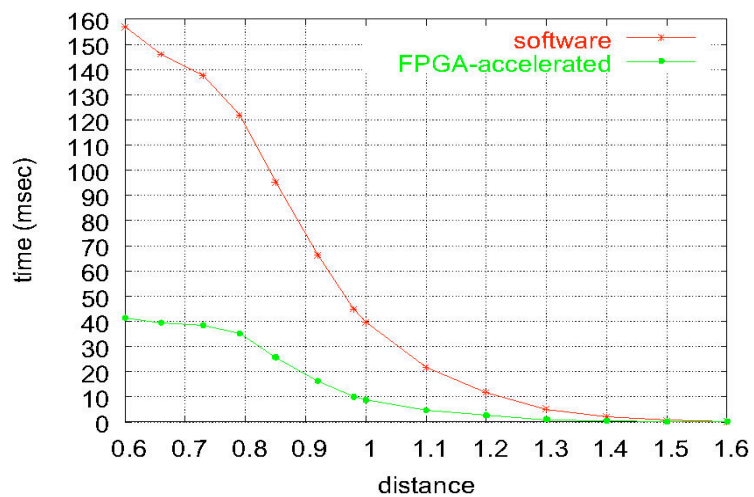

- FPGA-Implementation has no cache
- Using FPGA CPU is nearly completely idle

12

Future Work

- **SAT-Pipeline**
 - Determine optimal choice of parameters
- **Primitives**
 - Triangles
 - Quadrangles
 - NURBS
- **Memory-Interface**
 - Cache
 - Data-Compression
- **Deformable Objects**

13

Bibliography

- **Hardware-Accelerated Collision Detection using Bounded-Error Fixed-Point Arithmetic**
 - WSCG 2006
 - Andreas Raabe, Stefan Hochgürtel, Joachim K. Anlauf, Gabriel Zachmann
- **Technical Report TR-TI-2005-1 – Collision Detection for k-DOPs using SAT with Error Bounded Fixed-Point Arithmetic**
 - www.collisionchip.de
 - Stefan Hochgürtel, Andreas Raabe, Joachim K. Anlauf, Gabriel Zachmann
- **Hardware Accelerated Collision Detection - An Architecture and Simulation Results**
 - DATE 2005
 - Andreas Raabe, Blazej Bartyzel, Gabriel Zachmann, Joachim K. Anlauf
- **Hardwarearchitektur zur Kollisionserkennung**
 - Diploma Thesis
 - Blazej Bartyzel, University of Bonn, November 2003
- **Virtual Reality in Assembly Simulation - Collision Detection, Simulation Algorithms, and Interaction Techniques**
 - Dissertation, Fraunhofer IRB Verlag, ISBN 3-8167-5628-X
 - Gabriel Zachmann, University of Darmstadt, Mai 2000

14